

# JetBox 9310 / 9310-w

## Industrial PoE Networking Computer



CE FC cUL US LISTED RoHS

### JetBox 9310 Is a Patented 6-in-1 Industrial PoE Networking Computer

- **Industrial computer**  
RISC CPU, -40~80°C operating temp.(JetBox 9310-w)  
Linux programming & customized configuration auto-run  
Modbus gateway (optional)
- **Router**  
IP routed, static routing, NAT (firewall), DMZ
- **4-port PoE**  
4 ports follow IEEE802.3af 15.4W  
PoE scheduling
- **5-port Managed Ethernet switch**  
SNMP v1/v2c/v3  
QoS, VLAN (802.1Q, port-based)
- **4-port serial device server**  
VCOM, TCP server/ client, UDP
- **Digital I/O controller**  
4 DI & 4 DO  
DIO scheduling

- Industrial PoE Switch
- IP67/68 Ethernet Switch
- Rackmount Managed Switch
- Gigabit Switch
- Redundant Switch
- Entry-Level Switch
- Networking Computer**
- Communication Computer
- Ethernet I/O Server
- Serial Device Server
- Media Converter
- Multiport Serial Card
- SFP Module
- Din Rail Power Supply

## Overview

In a network environment, routers, switches and computers constitute a typical network architecture. While the technological development has advanced, so has the complexity of integrating these devices. Consequently the revolution of networking devices has begun. Functional integration and usability will be standard in next generation network devices.

JetBox 9310 is the communication platform that takes router functionality, managed PoE switching and computer functionality and rolls it all into one tiny box. Korenix provides not only API, but also the User

Interface to make managing the router, managed switch, and computer functionality simple.

JetBox 9310 is a RISC-based embedded computers, featuring 64MB of SDRAM system memory all major interfaces such as five Ethernet ports, two USB2.0 ports, two RS-232 ports, two RS-232/422/485 ports, four digital inputs, four digital outputs and one SD card slot. The built in Linux OS and essential network applications equips the JetBox 9310 to become a powerful network engine.

## Power over Ethernet

Power over Ethernet is an useful technology for powering devices where it would be inconvenient, expensive or unfeasible to supply power separately. JetBox 9310 implements the IEEE802.3af standard as a PSE (Power Sourcing Equipment) to provide 48 volts DC over two of the four available pairs on a Cat. 3/Cat. 5e/Cat6 cable with a maximum current of 400 mA for a maximum load power of 15.4W.

The IEEE802.3af standard describes two types of devices: PSE (Power Sourcing Equipment) and PD (Powered Device). PSE provides power to the PDs.

**PD classification:** detection, class ID 0~3 follow IEEE802.3af standard

**PIN assignment (RJ45 connector):** V+ (Pin 4,5), V- (Pin 7,8), Tx (Pin 1,2), Rx (Pin 3,6)

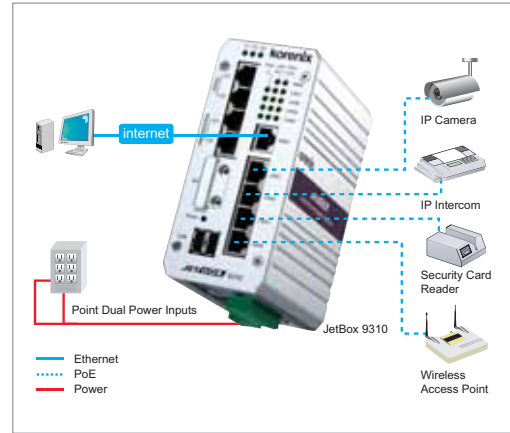

## SNMP Control & MIB

SNMP (Simple Network Management Protocol) which is used in networking management systems to monitor network-attached devices. JetBox 9310 provides complete SNMP v1, v2c, v3 protocol and MIBs (Management Information Bases). Customers can use one or more systems to manage a number of devices through JetBox 9310 SNMP control. MIB is a collection of network management information with organized hierarchy and can be accessed by using a network management protocol like SNMP. A MIB hierarchy can be illustrated as a MIB tree. Korenix provides the SNMP private MIB to let users compile it into the MIB browser.

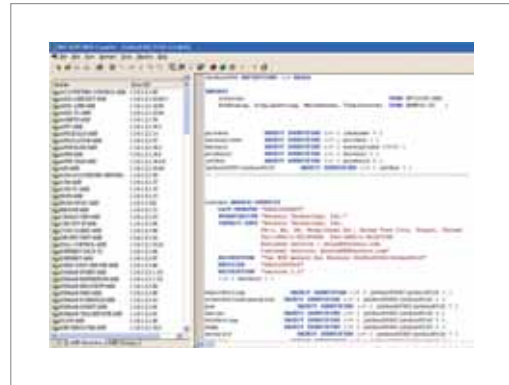

## JetBox Virtual COM Commander

Virtual COM can be useful in case there is a lack of available physical serial ports or to communicate with any other serial devices via internet or LAN (Serial-over-Ethernet technology). The physical communication can travel by software through TCP server/ client and UDP modes, and also through the virtual COM mode. Customers can install the virtual COM driver by installing JetBox Commander. Customers can manage virtual COMs through JetBox Commander.

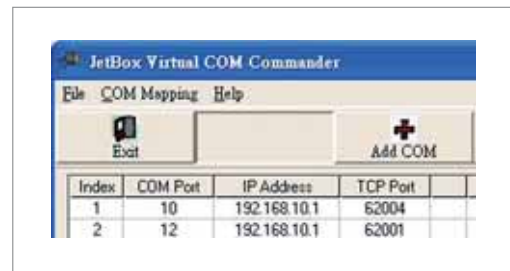

# Industrial Communication Computer

## User Interface: Web & CLI

Since the JetBox 9310 is a Linux-based computer, ideal for easy and powerful usage in networking environment, Korenix also provides a user friendly interface for router functionality, managed PoE

switch, and system settings. Users can set up those specific functions in Web user interface or Command line interface.

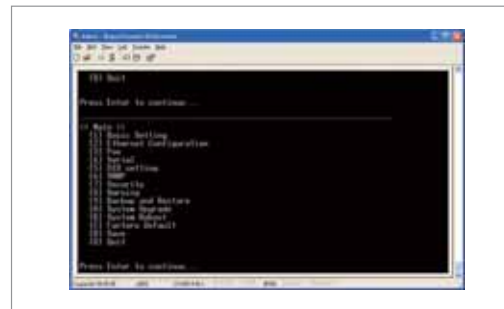

- Industrial PoE Switch
- IP67/68 Ethernet Switch
- Rackmount Managed Switch
- Gigabit Switch
- Redundant Switch
- Entry-Level Switch
- Networking Computer
- Communication Computer
- Ethernet I/O Server
- Serial Device Server
- Media Converter
- Multiport Serial Card
- SFP Module
- Din Rail Power Supply

## DIO Scheduling

Digital input and output are essential for control in industrial environment. JetBox 9310 not only focuses on network related functions, but also on industrial control. Hence, JetBox 9310 carries four digital inputs and four digital outputs for alarm, indicator, or sensor control. Further, the digital input and output of JetBox 9310 can be enabled or disabled based on schedule. Customers can set a scheduling table by Web UI or CLI.



## Router

There are five Ethernet ports of JetBox 9310. The default setting of Ethernet ports in JetBox 9310 is one WAN port and four LAN ports. Advanced Linux users can change the setting through JetBox 9310 Linux environment to provide the flexibility of adapting JetBox 9310 to various networking environments, such as using two WAN ports for two enterprises' networks as networking redundancy. When the Ethernet port of JetBox 9310 is set as WAN port, IP routing and static routing are supported.



## NAT (Network Address Translation) & DMZ (Demilitarized Zone)

NAT server enables a LAN to use one set of IP addresses for internal traffic and a second set of addresses for external traffic. Therefore, NAT server can provide a type of firewall by hiding internal IP addresses, enable a company to use more internal IP addresses without conflicting with IP addresses used by other companies, and allow a company to combine multiple ISDN connections into a single Internet connection.

JetBox 9310 provides NAT endpoint filtering as a firewall to protect customer's network from the outside world. Any incoming traffic must match the IP address of the outgoing connection when NAT endpoint filtering is enable. Sometimes, a customer will need to expose certain types of applications to the outside world. Therefore, JetBox 9310 also provides DMZ host function. Customers can place a computer in the DMZ to expose traffic to the Internet and run the application on that computer when DMZ host is enabled.

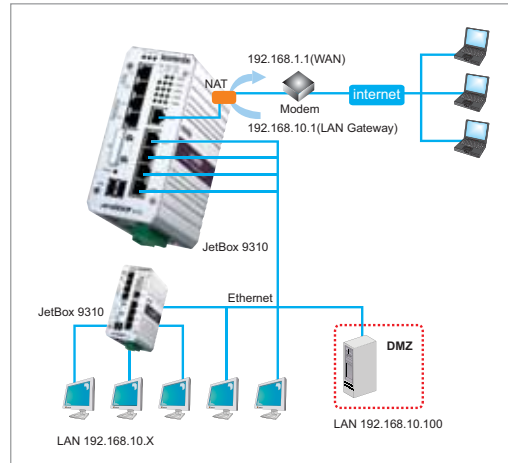

## Linux Environment

JetBox 9310 is designed as an industrial PoE networking computer based on the Linux operating system. Korenix provides the Web UI and CLI to make networking related setting simple. Since Linux is an open operating system, many users can concurrently access Linux environment. Therefore, Korenix also has ability to provide Linux environment for JetBox 9310. Advanced Linux users can manipulate with standard Linux command. Further, Korenix also provides JetBox 9310 Linux SDK for particular project users to develop their own applications. A suite of cross compilers, Linux tools, libraries, and header files are included in the JetBox 9310 Linux SDK.



## JetView (LAN IP Management)

JetView is a device management utility which support various device management features. Currently, JetBox supports JetView 1.1 (or above version) for device discovery and basic system LAN IP address modification. With different version, more features may be supported and you can always find the latest information in the Korenix web site or get help from Korenix Customer Support.

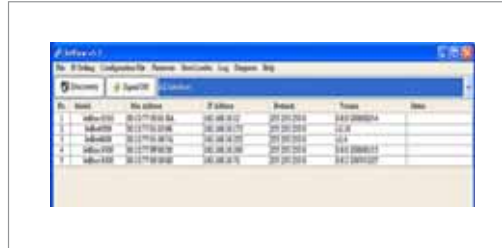

## Industrial Strength: IP31, Wide Temp, Vibration & Shock Resistance

IP (Ingress Protection) class defines the protection against contact and infiltration of water and dirt. In industrial applications, JetBox 9310 is designed to be set in the control box at the front end site, therefore the IP31 class protection make JetBox 9310 capable of withstanding rough conditions, dirt, dust and humidity.

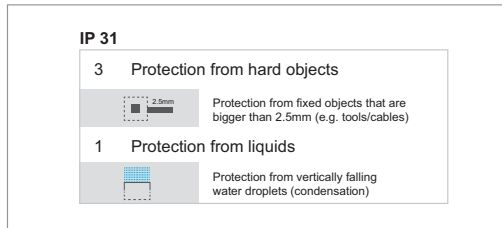

Besides water and dirt protection, JetBox 9310 also provides the wide temperature version (-40~80°C) to withstand high heat or cold environment.

\*model: JetBox 9310-w

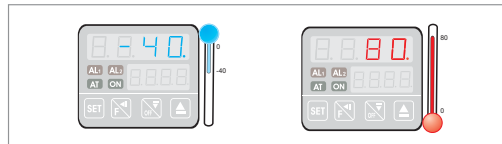

Further, some applications like monitoring in transportation and mining need high reliability to the resistance of shock and vibration. Solid hardware and mechanical design enables JetBox 9310 to sustain 5 gravities of vibration and 50 gravities of shock.



- Industrial PoE Switch
- IP67/68 Ethernet Switch
- Rackmount Managed Switch
- Gigabit Switch
- Redundant Switch
- Entry-Level Switch
- Networking Computer**
- Communication Computer
- Ethernet I/O Server
- Serial Device Server
- Media Converter
- Multiport Serial Card
- SFP Module
- Din Rail Power Supply

## Dimensions (Unit = mm)

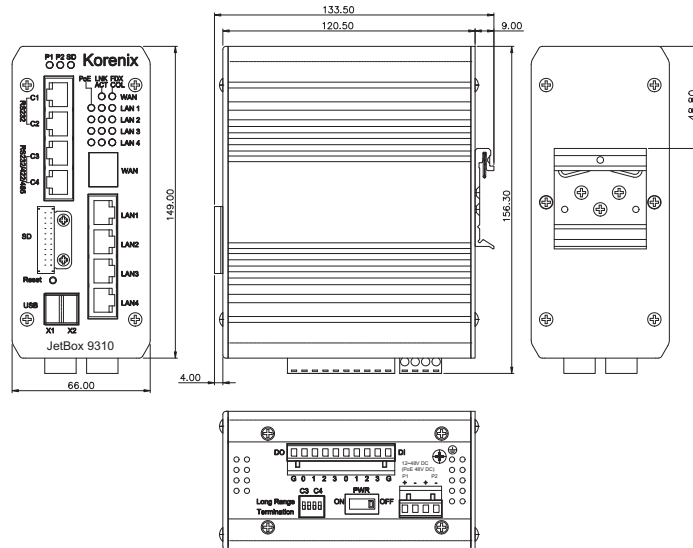

## Hardware Specifications

### System

**Processor:** RISC

**System memory:** SDRAM 64MB

**Ethernet:** 10/100 Based-Tx RJ-45 connector x5  
Built-in 15KV ESD protection of all signals

**SSD:** SD card slot x1

**Serial Port:**

RS-232 x2, RS-232/422/485 x2 (RJ45 connector)

**USB:** USB 2.0 x2 (Host)

Supporting devices: USB flash, wireless dongle

**Digital IO:** 4 DI & 4 DO

**LED per port:**

Link/Activity x5 (Green on/Green blinking)

Full Duplex/Collision x5 (Orange on/ Orange blinking)

**LED per PoE port (LAN1~LAN4):**

Powered/none x4(Green on/off)

**LED per unit:**

Power on/off x2 (Green on/off)

SD card x1 (Green plug/unplug)

**Power on/off switch x1**

**Reset button x1**

**HW Watchdog timer:**

Generates a time-out system reset, 1sec

**Power Supply:** DC input 48V

**Power Consumption:**

(NOT include PoE, PoE is 15.4W at 48V per port)

Single input 6.72W at 48V

Dual inputs 7.2W at 48V

**OS support:** Embedded Linux 2.6.21

### Mechanical

**Construction:**

Rugged Aluminum Alloy Chassis, IP31 protection

**Color:** Silver

**Mounting:** DIN rail

**Dimension:** 66(W) x149(H) x 120.5(D) mm

**Net weight:** 800g

### Environment

**Operating Temp:**

-4 ~ 158°F (-20 ~ 70°C), 5 to 95% RH

-40 ~ 176°F (-40 ~ 80°C)\*, 5 to 95% RH

(Wide temp. version) JetBox 9310-w

**Storage Temp:** -40 ~ 176°F(-40 ~ 80°C), 5 to 95% RH

**Regulation:** FCC class A, CE / UL

EN55022 class A

EN55024

EN61000-3-2, 3

EN61000-4-2, 3, 4, 5, 6, 8, 11

**EN 50155 Railway:** compliance

**Shock:** IEC60068-2-27 (50g peak acceleration)

**Vibration:** IEC60068-2-6 (5g/ 10~150Hz/operating)

**MTBF:** 319,175 hours MIL-HDBK-217 GB (MILITARY

HANDBOOK) standard

**Warranty:** 5 years

\*-40 ~ 60°C (UL regulations) up to 80°C has been

verified by korenix

## Software Specifications

### Embedded Linux

**Bootloader:** JetBox bootloader

**Linux Kernel:** 2.6.21

**Shell:** GNU ash

**File system:** jffs2

**Device drivers:** SD card, USB, Watchdog timer, UART

**Software packages:** busybox, bridge-utils, ethtool, iptables, net-snmp, ntp, openssh, openssl, pppd, rp-pppoe, syslogd, udhcp, setserial, goahead web server

### Technology

#### Standard:

IEEE802.3 10Base-T Ethernet

IEEE802.3u 100Base-Tx Fast Ethernet

IEEE802.3af Power over Ethernet (PoE)

IEEE802.3x Flow Control and Back-pressure

IEEE802.1p Class of service

IEEE802.1Q VLAN

**Processing:** Store and Forward architecture

**Packet filter:** Broadcast packet filtering

### PoE Technology

**PD classification:** detection, class ID 0~3 follow

IEEE802.3af standard

**PIN assignment (RJ45 connector):** V+ (Pin 4,5), V- (Pin 7,8), Tx (Pin 1,2), Rx (Pin 3,6)

**PoE control:** Support user configuration for PoE enable, disable, or based on schedule

**PoE schedule control:** Each PoE port can be active and powered scheduling with different rules. It supports weekly schedule on hourly basis.

**Power Limit Control:** The control mode supports IEEE802.3af standard. The maximum DC power delivery on each PoE is 15.4W@DC 48 V input

### Interface

**Number of Ports:** 5x 10/100 Base-Tx, auto MDI/MDI-X

**Network cables for PoE:**

10Base-T: 4-pair UTP/STP

Cat.3,4,5, EIA/TIA-568 100ohm (100m)

100Base-Tx: 4-pair UTP/STP

Cat.5 EIA/TIA-568 100ohm (100m)

### Routing

IP routed, static routing

Per VLAN routing

NAT/DMZ

ICMP, ARP

Block/Allow IP or port address

### Managed PoE Switch

**Configuration:** Web-interface, TFTP update, configuration backup and restore, DHCP client/server, warm reboot, reset to default, Admin password, Port speed/ Duplex control, Status and statistic display, SNMP v1/v2c/v3, Traps, RMON 1 (Statistics history, Alarm, Events), Command line interface

**MIB:** MIB-II, Bridge MIB, Ethernet-like MIB, VLAN MIB, Private MIB

**NTP** for time management

**VLAN:** Supports port-based VLAN and IEEE802.1Q VLAN

**Quality of Service:** Four priority queues per port, 802.1p

COS and IP Layer TOS/DiffServ

**IP address blocking:** Support IP address security to prevent unauthorized access

**E-mail warning, SMTP:** Automatic e-mail warning by pre-defined events

**System Event Log:** Support both local mode and server mode

### Ethernet Performance

**Transfer Rate:** 14,880 pps for Ethernet port and 148,800 pps for fast Ethernet port

**Transfer Packet Size:** 64 bytes to 1522 bytes (with VLAN tag)

**MAC address:** 1K MAC address table

**Memory Buffer:** 512 Kbits

**Back-plane:** 1.2 Gbps

Industrial PoE Switch

IP67/68 Ethernet Switch

Rackmount Managed Switch

Gigabit Switch

Redundant Switch

Entry-Level Switch

Networking Computer

Communication Computer

Ethernet I/O Server

Serial Device Server

Media Converter

Multiport Serial Card

SFP Module

Din Rail Power Supply

## Ordering Information

**JetBox 9310 RISC, 48V DC, 64MB SDRAM**

**JetBox 9310-w RISC, 48V DC, 64MB SDRAM, -40~80°C**

Includes:

- JetBox 9310 RISC industrial PoE Networking computer
- Serial cable (RJ45 to DB9 male, 150cm) x1
- 4-pin power terminal block
- 10-pin DIO terminal block
- Quick installation guide
- Documentation and software CD-ROM

## Optional Accessories

- Additional applications on SD card: SD card capacity is 1G SD1G-M Modbus gateway  
Advanced Linux configuration
- 802.11g wireless dongle for advanced Linux users
- Serial cables (RJ45 to DB9 male, 150cm)