



JetBox 8210 User Manual

Modbus Gateway

www.korenix.com

Copyright Notice

Copyright© 2007 Korenix Technology Co., Ltd.

All rights reserved.

Reproduction without permission is prohibited.

Information provided in this manual is intended to be accurate and reliable. However, the original manufacturer assumes no responsibility for its use, or for any infringements upon the rights of third parties that may result from its use. The material in this document is for product information only and is subject to change without notice. While reasonable efforts have been made in the preparation of this document to assure its accuracy, Korenix assumes no liabilities resulting from errors or omissions in this document, or from the use of the information contained herein.

Korenix reserves the right to make changes in the product design without notice to its users.

Acknowledgments

Korenix is a registered trademark of Korenix Technology Co., Ltd.

All other trademarks or registered marks in the manual belong to their respective manufacturers.

Table of Content

Copyright Notice	2
Acknowledgments.....	2
Table of Content.....	3
Chapter 1 Modbus TCP to RTU/ASCII Gateway Application	4
1-1 Overview	4
1-2 Arguments.....	5
1-3 Scenarios	5
1-4 Limitations.....	6
Chapter 2 Appendix	8
2-1 Chart Index.....	8
2-2 Customer Service	8

Chapter 1 Modbus TCP to RTU/ASCII

Gateway Application

1-1 Overview

Modbus is one of the most popular industrial protocols in the world. It is supported by the traditional RS-232/422/485 devices and recently by the Ethernet devices. Lots of industrial devices, such as PLCs, DCSs, HMIs, instruments, and meters, use Modbus as their communication standard.

A Modbus TCP to RTU/ASCII gateway application is designed as a bridge for the Modbus TCP (Ethernet) masters and Modbus RTU/ASCII (serial) slaves. It allows the Ethernet-based HMIs or PLCs to control devices over RS-232/422/485 without additional programming or effort.

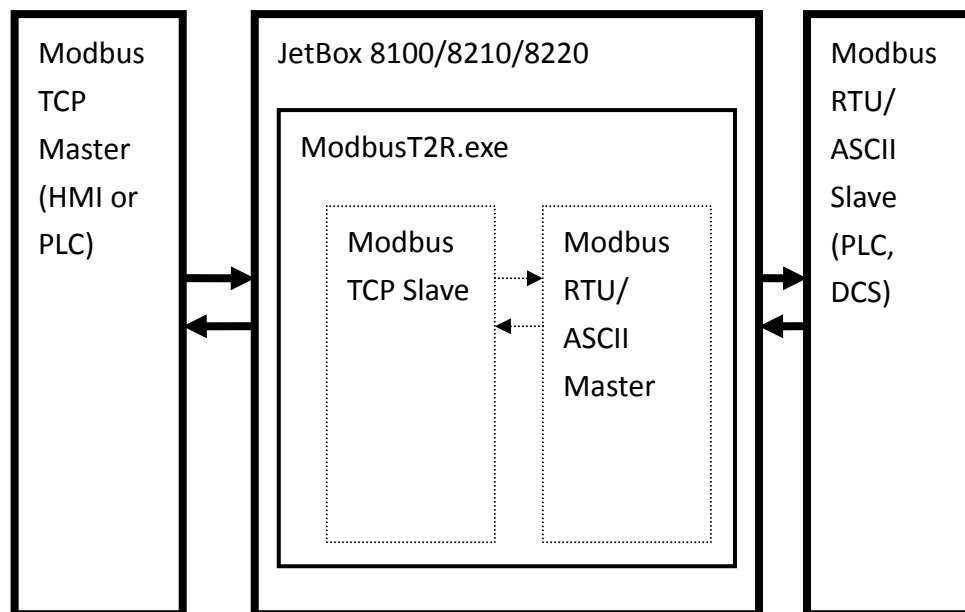

Chart 1 Block diagrams of Modbus TCP to RTU/ASCII gateway application

1-2 Arguments

The following command example, “-p 5501 -s COM1: -b 9600 -m RTU -id0 1 -id1 10”, means the gateway application creates one Modbus TCP slave service on TCP port 5501 and create one Modbus RTU master service on “COM1:” with 9600 baud rate and the valid Modbus RTU slave station ID is from 1 to 10.

Application Name: ModbusT2R.exe	
Arguments	Description
-help	Lists all the syntax of arguments.
-f [file name]	Specifies an argument file.
-p [TCP port number]	Specifies the TCP port number of Modbus TCP slave. Default port is 5501.
-s [serial port name]	Specifies the serial port name of Modbus RTU/ASCII master. Default port is “COM1:”.
-b [baud rate]	Specifies the baud rate of Modbus RTU/ASCII master. Default baud rate is 9600.
-m [“rtu” “ascii”]	Specifies the protocol of Modbus RTU/ASCII master. Default protocol is RTU.
-id0 [begin ID]	Specifies the begin ID of a range of Modbus slave ID. Default begin ID is 0.
-id1 [end ID]	Specifies the end ID of a range of Modbus slave ID. Default end ID is 247.

Chart 2 Description of the Arguments of the “ModbusT2R.exe” Application

1-3 Scenarios

The following script file, “demo.ini”, specifies one Modbus TCP slave service and one Modbus RTU master service and one Modbus ASCII master service.

Script File Name: demo.ini	
Contents	Description
-p 5501 -s COM1: -b 9600 -m RTU -id0 1 -id1 10	One Modbus TCP master on TCP port 5501 and One Modbus RTU master on serial “COM1:”. Valid station ID range from 1 to 10.

Script File Name: demo.ini

Contents	Description
-p 5501 -s COM2: -b 9600 -m	One Modbus TCP master on TCP port 5501 and
ASCII -id0 11 -id1 20	One Modbus ASCII master on serial "COM2:".
	Valid station ID range from 11 to 20.

Chart 3 Contents of the Script File "demo.ini"

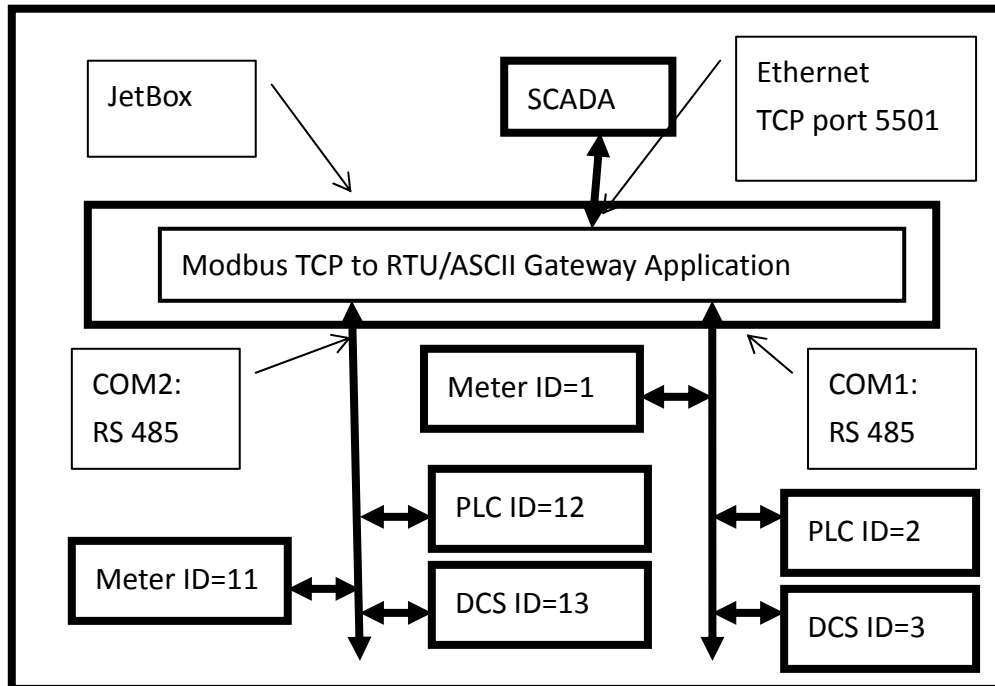

Chart 4 Scenario of running "ModbusT2R.exe" with "demo.ini" Script File

1-4 Limitations

Some limitations while running "ModbusT2R.exe" are detailed in the following table.

Application Name: ModbusT2R.exe	
Limitations	Description
No same station ID	Modbus station ID is used as an index for the gateway application in the current design, so Modbus RTU/ASCII slave device with the same station ID is not allowed to join the gateway network.
No TCP request buffering	Modbus TCP master is not allowed to

Application Name: ModbusT2R.exe	
Limitations	Description
	send multiple requests to slaves located in the Modbus RTU/ASCII network. Because no request buffering is supported, the request will be redirected to the specific serial port immediately. If it is a RS-485 serial port, a collision could happen.
No timeout	Modbus TCP to RTU/ASCII gateway application is designed without timeout mechanism. Modbus TCP master should take care of the response timeout for individual Modbus RTU/ASCII slaves.
No broadcast	Request for station ID 0 will not be broadcast to the Modbus serial network.
Hardcode serial parameters	The serial port parameters are hardcode to even parity, 8 data bits, 1 stop bit and none flow control for RTU protocol and even parity, 7 data bits, 1 stop bit and none flow control for ASCII protocol
One TCP port per instance	Only one Modbus TCP slave service will be created on the first specified TCP port number for one instance. Multiple instances of gateway application are allowed.
Executable without UI	A standalone executable and no UI available.
Not a service	It's not a service, no start and stop behaviors are supported.

Chart 5 Limitations while running “ModbusT2R.exe” application

Chapter 2 Appendix

2-1 Chart Index

Chart 1 Block diagrams of Modbus TCP to RTU/ASCII gateway application .. 4
Chart 2 Description of the Arguments of the “ModbusT2R.exe” Application
..... 5
Chart 3 Contents of the Script File “demo.ini” 6
Chart 4 Scenario of running “ModbusT2R.exe” with “demo.ini” Script File . 6
Chart 5 Limitations while running “ModbusT2R.exe” application 7

2-2 Customer Service



Korenix Technologies Co., Ltd.
9F, No. 100-1, Ming-Chuan Rd., Shing Tien City, Taipei, Taiwan

Tel:+886-2-82193000 Fax:+886-2-82193300

Business service: sales@korenix.com

Customer service: koreCARE@korenix.com

00.101.02